



# PNEUMATIC ACTUATED TRUE UNION BALL VALVES

## Spears® True Union 2000 Ball Valve Premium Pneumatic Actuation Package

The compact design of True Union 2000 Ball Valves provides maximum versatility with minimum space requirements. Fully serviceable valve cartridge also mates with Spears® Union 2000 Schedule 80 pipe unions. Both valves and unions utilize Buttress Thread union nuts for superior strength. All ball valves feature Spears® self adjusting Floating Seat design for extended service, and Spears® Safe-T-Shear® Stem with double O-ring stem seals for assurance of fluid containment in case of inadvertent valve damage. Available in chemical and corrosion resistant PVC or CPVC with socket, flanged or Spears® Patented Special Reinforced (SR) threaded.



Actuated package includes polypropylene valve mounting bracket for accurate valve/actuator alignment and support in any position. Premium pneumatic actuator is an Air-to-Air (Double Acting; optional Spring Return) featuring twin piston rack and pinion operation with adjustable stops, and permanent lubrication. Manual override is standard. Housing is hard anodized aluminum with epoxy coated aluminum end caps.

### True Union 2000 Ball Valve Specifications

Style	Double union • 1/4 turn shut off • Blocked seal carrier • Double O-ring stem seals • Safe-T-Shear® Stem
Material	PVC or CPVC
Size Range	1/2" - 6" & 8" Venturied*
Pressure Rating	1/2" - 4" = 235 psi @ 73° F 6" - 8" & all flanged valves = 150 psi @ 73° F
Vacuum Service	To 26 in-Hg
Seats	PTFE
O-rings	EPDM or Viton®
End Connector	Socket, SR Threaded, or Flanged
Certifications	NSF Certified for potable water use.

\*8" Venturied is 6" valve fitted with 8 x 6 adapters

### Standard 2-Position Actuator Specifications

Type	Dual piston • rack & pinion • adjustable stop
Standard Operation	Air-to-Air (double acting)
Supply Pressure	80 psi
Air Connection	1/4" - 1/8"
Position Indicator	Pointer-Standard
Manual Override	Standard
Body	Hard anodized aluminum
End Caps	Epoxy coated aluminum

### Custom Pneumatic Actuation Options & Accessories

- Spring Return Operation (Fail Safe)
- 60 psi or 40 psi Operating Pressure
- Declutchable Manual Override
- Pneumatic & Electro Pneumatic Positioners
- 3 & 4 Way Solenoid Valve  
12VDC, 24VDC, 115VAC, 230VAC  
NEMA 4/4x & 7/9 rating
- Dual Power Solenoids
- Output Signal Limit Switches
- Standard Limit Switches
- Dome Position Indicator
- Stainless Steel Gauge Sets
- Customized ID Tags

### Sample Engineering Specification

All ball valves shall be pneumatically actuated True Union 2000 type constructed from PVC Type I Cell Classification 12454 or CPVC Type IV Cell Classification 23447. All O-rings shall be EPDM or Viton®. All valves shall have Safe-T-Shear® stem and double O-ring stem seals. All valve union nuts shall have Buttress threads. All seal carriers shall be Safe-T-Blocked®. All valve components shall be replaceable. All valves shall be Certified by NSF International for use in potable water service. All 1/2" through 4" valves shall be pressure rated at 235 psi and all 6" through 8" and all flanged valves shall be pressure rated at 150 psi for water at 73° F. Pneumatic Actuators shall be factory installed, dual piston, rack & pinion design with adjustable stops. Operation shall be Air-to-Air (double acting) for 80 psi supply pressure. All mounting fasteners shall be stainless steel. Actuator shall be equipped with [selected options list], as manufactured by Spears® Manufacturing Company.

# PNEUMATIC ACTUATED TRUE UNION BALL VALVES



## Standard Package Dimensional Information:

1/2" TO 6" - INDUSTRIAL 2000  
BALL VALVE W/PNEUMATIC ACTUATOR

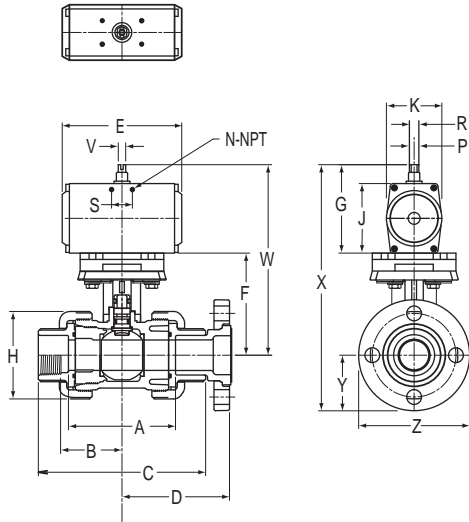

FIG. I FOR 1/2 TO 1-1/4 BALL VALVE

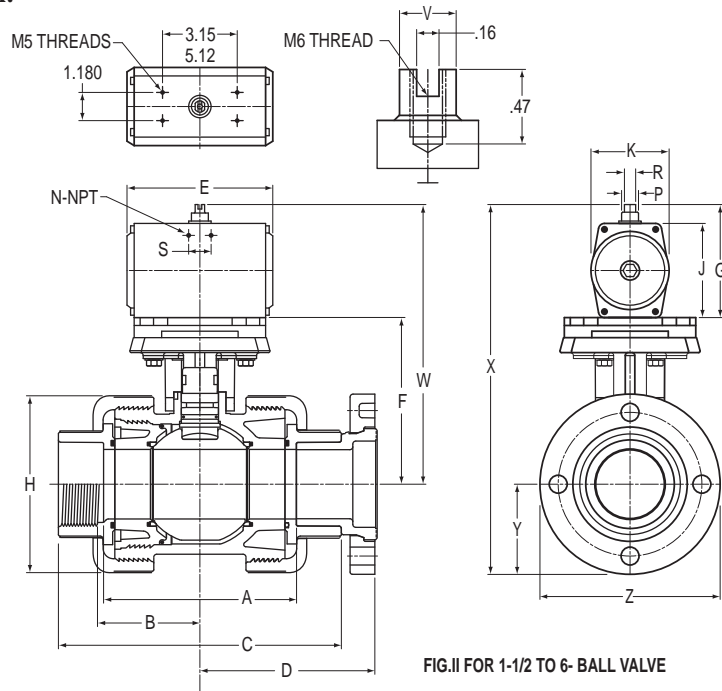

FIG. II FOR 1-1/2 TO 6 BALL VALVE

NOMINAL SIZE	A	B	C		D	E		F	G		H	J
			SOCKET	THREAD		AIR TO AIR	AIR TO SPRING		AIR TO AIR	AIR TO SPRING		
1/2	2.44	1.19	4.19	3.81	2.95	5.00	5.00	3.31	3.82	3.82	1.88	2.91
3/4	2.75	1.40	4.75	4.25	3.32	5.00	5.00	3.50	3.82	3.82	2.25	2.91
1	2.88	1.45	5.13	4.69	3.57	5.00	5.00	3.63	3.82	3.82	2.50	2.91
1-1/4	3.25	1.66	5.75	5.19	3.82	5.00	5.00	4.76	3.82	3.82	3.06	2.91
1-1/2	3.50	1.77	6.25	5.44	4.16	5.00	5.00	5.25	3.82	3.82	3.50	2.91
2	4.75	2.39	7.75	6.75	5.00	5.00	5.24	5.76	3.82	4.37	4.25	3.46
2-1/2	6.95	3.47	10.44	9.68	6.70	5.00	6.10	7.00	3.82	4.84	6.19	3.94
3	6.95	3.47	10.69	9.75	6.98	5.00	6.10	7.00	3.82	4.84	6.19	3.94
4	7.31	3.65	11.87	10.25	7.44	6.10	7.99	8.50	4.84	5.55	7.50	4.61
6	11.03	5.50	17.13	15.75	10.15	7.99	11.18	9.29	5.55	6.71	11.63	5.51

K		N	P	R	S	V	W		X		Y	Z	FIG.
AIR TO AIR	AIR TO SPRING						AIR TO AIR	AIR TO SPRING	AIR TO AIR	AIR TO SPRING			
2.32	2.32	1/4	.79	.47	.94	.390	7.13	7.13	8.88	8.88	1.75	3.50	I
2.32	2.32	1/4	.79	.47	.94	.390	7.32	7.32	9.25	9.25	1.93	3.86	I
2.32	2.32	1/4	.79	.47	.94	.390	7.45	7.45	9.58	9.58	2.13	4.25	I
2.32	2.32	1/4	.79	.47	.94	.390	8.58	8.58	10.88	10.88	2.30	4.61	I
2.32	2.32	1/4	.79	.47	.94	.390	9.07	9.07	11.56	11.56	2.49	4.98	II
2.32	2.76	1/4	.79	.47	.94	.390	9.58	10.13	12.56	13.11	2.98	5.96	II
2.32	3.27	1/4	1.02	.55	.94	.390	10.82	11.84	14.57	15.59	3.75	7.50	II
2.32	3.27	1/4	1.02	.55	.94	.390	10.82	11.84	14.57	15.59	3.75	7.50	II
3.27	3.94	1/4	1.38	.79	.94	.550	13.34	14.05	17.92	18.63	4.58	9.15	II
3.94	4.72	1/4	1.97	1.10	.94	.790	14.84	16.00	20.66	21.82	5.82	11.25	II