

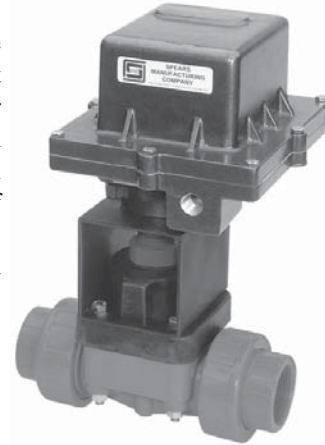

ELECTRIC ACTUATED DIAPHRAGM VALVES

Spears® Diaphragm Valve Premium Electric Actuation Package

This full-featured industrial grade valve is engineered to provide accurate throttling and shut off for chemical processing, industrial, and water treatment applications. Weir type design eliminates entrapped fluids in valve. Excellent for handling of liquids with suspended solids, viscous materials and slurries. Premium electric actuator utilizes a multi-turn reversing motor with UL approved, built in thermal overload protection and permanently lubricated gear train. Weatherproof NEMA 4 enclosure is corrosion resistant polyester powder coated aluminum, 1/2" NPT conduit outlet. Includes 2-SPDT limit switches pre-wired for standard 115 VAC, 60 Hz.



Diaphragm Valve Specifications

Style	Diaphragm • Weir type • fully repairable
Material	PVC, CPVC, UV Stabilized PP
Size Range	1/2" - 8"
Pressure Rating	PVC & CPVC 1/2" - 2" = 235 psi @ 73°F 1/2" - 4" Flanged = 150 psi @ 73°F 6" = 100 psi @ 73°F 8" = 75 psi @ 73°F PP: 1/2" - 4" = 150 psi @ 73°F 6" = 100 psi @ 73°F 8" = 75 psi @ 73°F With PTFE Diaphragm: 1/2" - 4" = 150 psi @ 73°F
Diaphragm	EPDM, Viton®, or elastomer backed PTFE
End Connector	PVC & CPVC = True Union socket/threaded, or Spigot Body (1/2" - 2") Flanged Body (1/2" - 8") PP: True Union threaded (1/2" - 2"), Flanged Body (sizes 2-1/2" - 8")

Standard 2-Position Actuator Specifications

Motor	Multi-turn reversing
Thermal Overload Protection	Standard
Cycle Time (open - close)	1/2" - 1-1/2" = 2 min. 2" = 10 min. 2-1/2" - 3" = 2 min. 4" = 1 min. 6" - 8" = TBA
Duty Cycle	25%, 75%
Manual Override	Optional
Torque Sensor	Optional
Limit Switch	2, SPDT pre-wired
Enclosure	NEMA 4/4X 1/2" NPT connection
Material/Finish	Aluminum /Powder Coated
Voltage	115 VAC, 60 Hz
Lock Rotor Current	1/2" - 2" = 0.75 amps 2-1/2" - 3" = 1.5 amps 4" = 7.5 amps 6" - 8" = TBA
Lubrication	Permanent

Special Valve Options & Accessories

- Diaphragm & O-ring Replacement Kits
- Hypalon® (CSM) Diaphragms
- EPDM backed PTFE Diaphragms
- Viton® backed PTFE Diaphragms

Custom Electric Actuation Options & Accessories

- Declutchable Manual Override
- Auxiliary Limit Switches
- NEMA 7, & 9 Enclosures
- Position Indicator Lights (red/green)
- Voltage Options: 12 VDC, 24 VDC,
24 VAC, 230 VAC
(see Accessories & Options section for limitations)
- Custom ID Tags

Sample Engineering Specification

All electrically actuated diaphragm valves shall be True Union Socket/Thread or Flanged or Spigot type constructed from PVC Type I Cell Classification 12454 or CPVC Type IV Cell Classification 23447 or UV Stabilized PP. All valve diaphragms shall be EPDM or Viton® or Hypalon® or elastomer backed PTFE. All True Union valve union nuts shall have Buttress threads. All valve components shall be replaceable. All 1/2" through 2" valves shall be pressure rated to 235 psi, all 2-1/2" through 4" valves, 1/2"- 4" flanged valves and 1/2" - 4" PTFE diaphragm valves to 150 psi, all 6" valves to 100 psi, and all 8" valves to 75 psi for water at 73° F. Electric Actuators shall be factory installed, 115 VAC with thermally protected, reversing motor and powder coated NEMA 4 rated enclosure. Actuator shall be equipped with [selected options list] as manufactured by Spears® Manufacturing Company.

ELECTRIC ACTUATED DIAPHRAGM VALVES



Diaphragm Valve Wiring Schematic

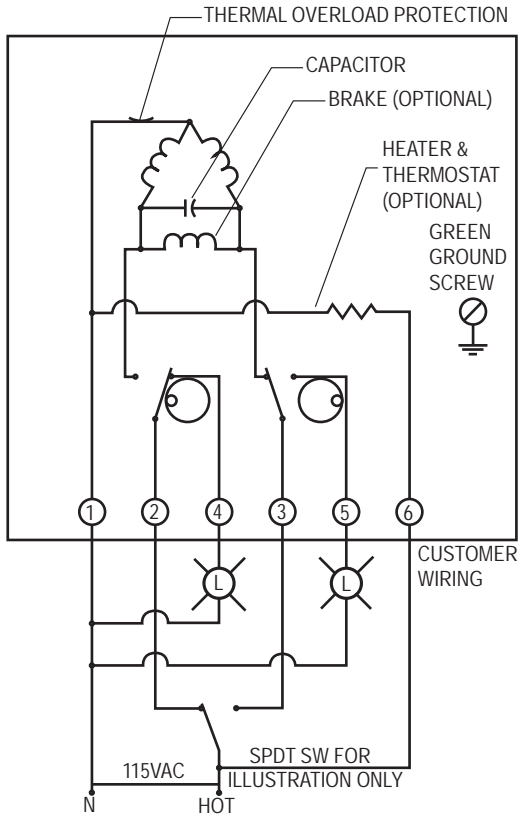

Actuator shown in open position
 Power to #1 & #2 To Open
 Power to #1 & #3 To Close

When the actuator is over torqued or in a stall condition, the current draw increases and the current sensor detects the increase. Upon exceeding the thermal coupling overload the circuit opens and actuator shuts off. Once temperature reduces, thermal coupler will reconnect and actuator will operate.

This wiring diagram illustrates connection for heater, thermostat, indicator lights, and two auxiliary switches (all optional).



ELECTRIC ACTUATED DIAPHRAGM VALVES

Standard Package Dimensional Information

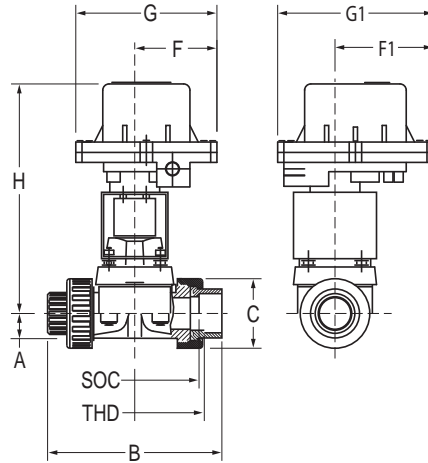

Electric Diaphragm Valve - Socket/Threaded

Size	A	B	C	F	F1	G	G1	H	Socket	Thread
1/2	9/16	5-17/32	1-15/16	4-31/32	5-15/16	8-1/2	9-3/8	12-13/16	1-29/32	2-1/16
3/4	23/32	6-1/2	2-1/2	4-31/32	5-15/16	8-1/2	9-3/8	12-31/32	2-1/4	2-17/32
1	27/32	7-1/4	2-7/8	4-31/32	5-15/16	8-1/2	9-3/8	13-5/32	2-1/2	2-3/4
1-1/4	1-9/32	8	5-5/16	4-31/32	5-15/16	8-1/2	9-3/8	13-15/32	2-3/4	3-1/16
1-1/2	1-9/32	9-1/16	3-17/32	4-31/32	5-15/16	8-1/2	9-3/8	13-15/32	3-5/32	3-19/32
2	1-1/2	10-1/2	4-7/32	4-31/32	5-15/16	8-1/2	9-3/8	13-27/32	3-3/4	4-1/4

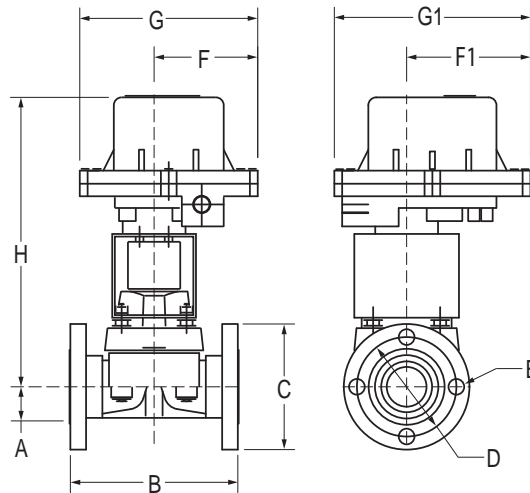

Electric Diaphragm Valve - Flanged

Size	A	B	C	D	E	F	F1	G	G1	H
1/2	9/16	4-5/8	3-1/2	2-3/8	5/8	4-31/32	5-15/16	8-1/2	9-3/8	12-11/16
3/4	23/32	5	3-7/8	2-3/4	5/8	4-31/32	5-15/16	8-1/2	9-3/8	12-31/32
1	27/32	5-5/8	4-1/4	3-1/8	5/8	4-31/32	5-15/16	8-1/2	9-3/8	13-5/32
1-1/4	1-9/32	6-1/2	4-5/8	3-1/2	5/8	4-31/32	5-15/16	8-1/2	9-3/8	13-15/32
1-1/2	1-9/32	6-3/4	5	3-7/8	5/8	4-31/32	5-15/16	8-1/2	9-3/8	13-15/32
2	1-1/2	8	6	4-3/4	3/4	4-31/32	5-15/16	8-1/2	9-3/8	13-27/32

ELECTRIC ACTUATED DIAPHRAGM VALVES



Standard Package Dimensional Information

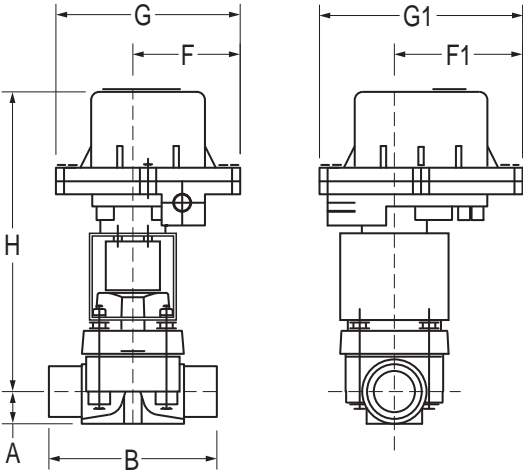

Electric Diaphragm Valve - Spigot

Size	A	B	F	F1	G	G1	H
1/2	9/16	4-3/8	4-31/32	5-15/16	8-1/2	9-3/8	12-13/16
3/4	23/32	4-3/4	4-31/32	5-15/16	8-1/2	9-3/8	12-31/32
1	27/32	5-3/8	4-31/32	5-15/16	8-1/2	9-3/8	13-5/32
1-1/4	1-9/32	6-1/4	4-31/32	5-15/16	8-1/2	9-3/8	13-15/32
1-1/2	1-9/32	6-1/2	4-31/32	5-15/16	8-1/2	9-3/8	13-15/32
2	1-1/2	7-3/4	4-31/32	5-15/16	8-1/2	9-3/8	13-27/32

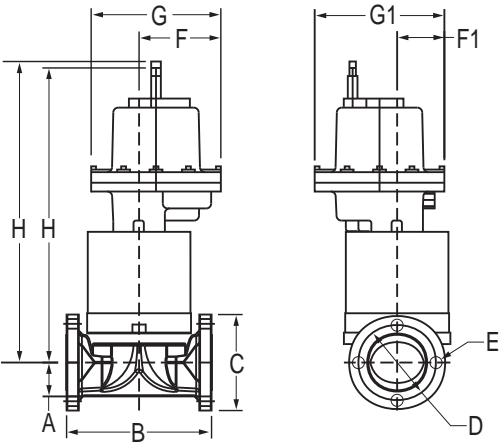

Electric Diaphragm Valve - Flanged 2-1/2" - 8"

Size	A	B	C	D	E	F	F1	G	G1	H	
										Open	Close
2-1/2	2-5/8	7/32	7-1/2	5-1/2	3/4	6-11/32	3-11/16	10-1/16	10-1/16	22-27/32	22-11/32
3	2-5/8	11-3/16	7-1/2	6	3/4	6-11/32	3-11/16	10-1/16	10-1/16	22-27/32	22-11/32
4	TBA										
6	TBA										
8	TBA										