



# TRUE UNION BALL CHECK VALVES (REGULAR STYLE)



## Sample Engineering Specification

All thermoplastic check valves shall be True Union Ball type constructed from PVC Type I, ASTM D 1784 Cell Classification 12454 or CPVC Type IV, ASTM D 1784 Cell Classification 23447. All O-rings shall be EPDM or Viton®. All valve union nuts shall have Buttress threads. All valve components shall be replaceable. All valves shall be certified by NSF International for use in potable water service. All 1/2" - 2" valves shall be pressure rated at 235 psi and all 2-1/2" - 6" and all flanged valves shall be pressure rated at 150 psi for water at 73°F, as manufactured by Spears® Manufacturing Company.

## Quick-View Valve Selection Chart

Valve Size	O-ring Material	PVC Part Number <sup>1</sup>			Pressure Rating
		Threaded	Socket	Flanged	
1/2	EPDM	2229-005	included	2223-005	235 psi Non-Shock Water @ 73°F
	Viton®	2239-005	included	2233-005	
3/4	EPDM	2229-007	included	2223-007	
	Viton®	2239-007	included	2233-007	
1	EPDM	2229-010	included	2223-010	
	Viton®	2239-010	included	2233-010	
1-1/4	EPDM	2229-012	included	2223-012	(Flanged 150 psi Non-Shock) Water @ 73°F
	Viton®	2239-012	included	2233-012	
1-1/2	EPDM	2229-015	included	2223-015	
	Viton®	2239-015	included	2233-015	
2	EPDM	2229-020	included	2223-020	150 psi Non-Shock Water @ 73°F
	Viton®	2239-020	included	2233-020	
2-1/2	EPDM	2221-025	2222-025	2223-025	
	Viton®	2231-025	2232-025	2233-025	
3	EPDM	2221-030	2222-030	2223-030	
	Viton®	2231-030	2232-030	2233-030	
4	EPDM	2221-040	2222-040	2223-040	
	Viton®	2231-040	2232-040	2233-040	
6 <sup>2</sup> venturied	EPDM	---	2222-060	2223-060	
	Viton®	---	2232-060	2233-060	

1: For CPVC valves, add the letter "C" to part numbers listed (e.g., 2239-005C).  
2: Consists of 4" True Union Ball Valve with two 4" x 6" Adapters.

## Features – PVC, CPVC

Flow tested design provides quick response with positive seal for prevention of system back flow in industrial and chemical processing applications. Available in IPS Sizes 1/2"- 4" with socket, threaded or flanged end connectors. 6" Venturied valve (4" valve with 4 x 6 adapters) available with either socket or flanged end connection. Also available with metric 20mm - 110mm or 1/2" - 4" BSP thread end connectors. **Note:** Seal carrier is **NOT** blocked (for Safe-T-Blocked® seal carrier design, see True Union 2000 Industrial Ball Check Valve).

- Chemical & Corrosion Resistant PVC or CPVC Construction
- Strong, Buttress Thread Union Nuts
- Fully Serviceable, Replaceable Components
- Uses Standard O-ring Seat
- EPDM or Viton® O-rings
- Sizes 1/2" - 2" Pressure Rated to 235 psi @ 73°F, Sizes 2-1/2" - 6" and all Flanged Pressure Rated to 150 psi @ 73°F
- Suitable for Either Horizontal or Vertical Installations
- NSF Certified for Potable Water use
- Suitable for Vacuum Service
- Assembled with Silicone-Free, Water Soluble Lubricants
- Manufactured to ASTM F 1970

## Ball Check Foot Valves

Spears® Ball Check Valves easily convert to foot valves utilizing optional Foot Valve Screen adapters found in Ball Valve Accessories section.



# TRUE UNION BALL CHECK VALVES (REGULAR STYLE)

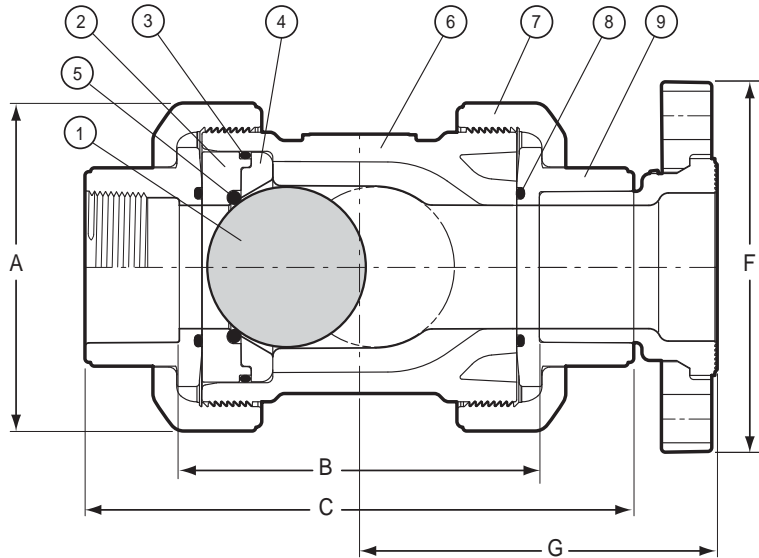

## Replacement Parts

No.	Component	Qty.	Material
1	Ball	1	PVC/CPVC
2	Seal Carrier	1	PVC/CPVC
3	Carrier O-ring	1	EPDM/Viton®
4	Seat Plate	1	PVC/CPVC
5	Seat O-ring	1	EPDM/Viton®
6	Body	1	PVC/CPVC
7	Union Nut	2	PVC/CPVC
8	End Connector O-ring	2	EPDM/Viton®
9	End Connector	2	PVC/CPVC

## Dimensions, Weights, C<sub>v</sub> Values & Horizontal Closing Requirements

Nominal Size	Dimension Reference (inches, ± 1/16)					Approx. Wt. (Lbs.)		C <sub>v</sub> Values		Horizontal Closing	
	A	B <sup>1</sup>	C	F	G	PVC	CPVC	Threaded/Socket	Flanged	Feet of Head (water)	GPM (minimum)
1/2	2-9/16	3-5/16	5-1/8	3-1/2	3-7/16	.56	.61	11	10	1.6	.10
3/4	3	4	6-1/8	3-7/8	3-15/16	.91	.99	18	17	1.6	.10
1	3-7/16	4-1/4	6-1/2	4-1/4	4-3/8	1.20	1.30	32	30	1.6	.25
1-1/4	3-11/16	4-1/2	7	4-5/8	4-9/16	1.50	1.60	58	55	1.6	.40
1-1/2	4-3/8	5-5/16	8-1/16	5	5-1/4	2.50	2.70	94	89	1.6	.75
2	5-1/8	5-3/4	8-3/4	6	5-5/8	3.70	4.00	153	146	1.6	.75
2-1/2	7-3/8	8-5/16	11-7/8	7	7-1/4	11.10	12.21	159	155	1.0	1.50
3	7-3/8	8-1/8	11-7/8	7-1/2	7-1/2	10.84	11.91	378	361	1.0	4.00
4	8-15/16	8-1/4	12-15/16	9-1/16	8-1/8	17.60	19.36	551	537	1.0	5.50
6 Socket <sup>2</sup>	8-15/16	19-5/8	26-1/16	N/A	N/A	22.45	27.61	N/A	N/A	N/A	N/A
6 Flanged <sup>2</sup>	11-3/16	29-3/8	N/A	11-1/4	14-3/4	31.21	37.07	N/A	N/A	N/A	N/A

- 1: Valve Lay Length  
 2: Consists of 4" True Union Ball Check Valve with two 4" x 6" Adapters.  
 3: Gallons per minute at 1 psi pressure drop.  
 C<sub>v</sub> Values for 6" venturied flange and socket valves are not available.

## Temperature Pressure Rating

System Operating Temperature °F (°C)		100 (38)	110 (43)	120 (49)	130 (54)	140 (60)	150 (66)	160 (71)	170 (77)	180 (82)	190 (88)	200 (93)	210 (99)	
Valve Pressure Rating psi (MPa)	1/2" - 2"	PVC	235 (1.62)	211 (1.45)	150 (1.03)	75 (.52)	50 (.34)	-0- (-0-)	-0- (-0-)	-0- (-0-)	-0- (-0-)	-0- (-0-)	-0- (-0-)	
		CPVC	235 (1.62)	219 (1.51)	170 (1.17)	145 (1.00)	130 (.90)	110 (.76)	90 (.62)	80 (.55)	70 (.48)	60 (.41)	50 (.34)	-0- (-0-)
	2-1/2" - 6"	PVC	150 (1.03)	135 (.93)	110 (.76)	75 (.52)	50 (.34)	-0- (-0-)	-0- (-0-)	-0- (-0-)	-0- (-0-)	-0- (-0-)	-0- (-0-)	-0- (-0-)
		CPVC	150 (1.03)	140 (.97)	130 (.90)	120 (.83)	110 (.76)	100 (.70)	90 (.62)	80 (.55)	70 (.48)	60 (.41)	50 (.34)	-0- (-0-)

NOTE: Flanged Valves have a base pressure rating of 150 psi.

**General Installation Information:** Ball check valves may be installed in either horizontal or vertical position. A minimum of ten (10) pipe diameters distance maintained from any pump or other source of turbulence. Ball Check valves **MUST** be installed with the valves **FLOW** arrow pointing in the direction of flow.

**NOT FOR USE WITH COMPRESSED AIR OR GASES**