



# GATE VALVES

## Features – PVC, CPVC

This solid, proven design is well suited for a variety of chemical, industrial and irrigation applications. Spears® Gate Valves are feature-packed with a variety of end connector options. Individual special features are found in each size range 1/2" through 2", 2-1/2" & 3", and in the full featured Heavy Industrial 4" valve. See Spears® Plug Gate Valves for 6" size.

- Heavy Bodied PVC & CPVC Construction
- Tapered Wedge with Specially Designed Sealing Surface
- Non-Rising Stem Design
- Patented Strain-Equalizing Stem/Wedge Thread
- O-ring Stem Seals Instead of Packing - No Retightening Required
- Buna-N, EPDM, or Viton® O-ring Seals
- Positive Grip, High Impact Polypropylene Handwheel Operator
- Fully Serviceable, Replaceable Components - Accessible Without Valve Removal
- NSF Certified for Potable Water use
- Suitable for Vacuum Service
- Assembled with Silicone-Free, Water Soluble Lubricants
- Metric Socket and BSP Thread Available, 1/2" - 2"



### 1/2" - 2" PVC & CPVC Heavy Duty Gate Valves

- Available with socket, threaded or flanged end connectors.
- Pressure rated to 200 psi @ 73°F. Flanged Valve Pressure Rated to 150 psi @ 73°F

### 2-1/2" & 3" PVC & CPVC Heavy Duty Gate Valves

- Available with socket, SR Threaded (Special Reinforced) threaded or flanged end connectors.
- Pressure rated to 150 psi @ 73°F.
- Optional 2" Square/T-Style Operator Nut available.

**Note:** 2-1/2" size is a bushed down 3" valve.

### 4" PVC & CPVC Heavy Industrial Gate Valves

- Available with socket, SR Threaded (Special Reinforced) threaded or flanged end connectors.
- Pressure rated to 235 psi @ 73°F. Flanged Valve Pressure Rated to 150 psi @ 73°F
- SS 316 Exterior Bonnet & Hardware
- Built-in Quick-View Position Indicator
- Optional 2" Square/T-Style Operator Nut available.

## Sample Engineering Specification

All thermoplastic Gate Valves shall be constructed from PVC Type I Cell Classification 12454 or CPVC Type IV Cell Classification 23447. All O-rings shall be Buna-N, EPDM or Viton®. All valves shall have non-rising stem and Polypropylene handwheel. All valve gate wedges shall have Strain-Equalizing threads. PVC valves shall have Polypropylene wedge and CPVC valves shall have CPVC wedge. All valve components shall be replaceable. All 1/2" through 2" valves shall be pressure rated at 200 psi, all 2-1/2" through 3" valves shall be pressure rated at 150 psi, and all 4" valves shall be pressure rated at 235 psi for water at 73°F, as manufactured by Spears® Manufacturing Company.

# GATE VALVES



## Quick-View Valve Selection Chart

Valve Size	O-ring Material	PVC Part Numbers <sup>1</sup>			Pressure Rating	
		Socket	Threaded	Flanged		
1/2	Buna-N	2012-005	2011-005	2013-005	200 psi Non-Shock Water @ 73°F	
	EPDM	2022-005	2021-005	2023-005		
	Viton®	2032-007	2031-005	2033-005		
3/4	Buna-N	2012-007	2011-007	2013-007		
	EPDM	2022-007	2021-007	2023-007		
	Viton®	2032-007	2031-007	2033-007		
1	Buna-N	2012-010	2011-010	2013-010		
	EPDM	2022-010	2021-010	2023-010		
	Viton®	2032-010	2031-010	2033-010		
1-1/4	Buna-N	2012-012	2011-012	2013-012		(Flanged 150 psi Non-Shock Water @ 73°F)
	EPDM	2022-012	2021-012	2023-012		
	Viton®	2032-012	2031-012	2033-012		
1-1/2	Buna-N	2012-015	2011-015	2013-015		
	EPDM	2022-015	2021-015	2023-015		
	Viton®	2032-015	2031-015	2033-015		
2	Buna-N	2012-020	2011-020	2013-020		
	EPDM	2022-020	2021-020	2023-020		
	Viton®	2032-020	2031-020	2033-020		
2-1/2	Buna-N	2012-025 <sup>3</sup>	2011-025 <sup>3</sup>	2013-025 <sup>3</sup>	150 psi Non-Shock Water @ 73°F	
	EPDM	2022-025 <sup>3</sup>	2021-025 <sup>3</sup>	2023-025 <sup>3</sup>		
	Viton®	2032-025 <sup>3</sup>	2031-025 <sup>3</sup>	2033-025 <sup>3</sup>		
3	Buna-N	2012-030	2011-030SR	2013-030		
	EPDM	2022-030	2021-030SR	2023-030		
	Viton®	2032-030	2031-030SR	2033-030		
4	Buna-N	2012-040	2011-040SR	2013-040	235 <sup>2</sup> psi Non-Shock Water @ 73°F	
	EPDM	2022-040	2021-040SR	2023-040		
	Viton®	2032-040	2031-040SR	2033-040		

- 1: For CPVC valves, add the letter "C" to the part numbers (e.g., 2031-005C).  
 2: Flanged end connectors have a Maximum Internal Pressure Rating of 150 psi @ 73°F.  
 3: Outlet sized with bushing.

## C<sub>v</sub> Values

Nominal Size	C <sub>v</sub> <sup>1</sup> Gallons/Minute	
	Socket/Threaded	Flanged
1/2	19	15
3/4	37	29
1	44	39
1-1/4	128	105
1-1/2	144	127
2	333	279
2-1/2	See Note 2	
3	335	323
4	583	566

- Flanged valves calculated for additional laying length of flanged valve.  
 1: Gallons per minute at 1 psi pressure drop.  
 2: Size 2-1/2" is a reducer bushed down 3" valve, C<sub>v</sub> not available.

## Temperature Pressure Rating

System Operating Temperature °F (°C)		100 (38)	110 (43)	120 (49)	130 (54)	140 (60)	150 (66)	160 (71)	170 (77)	180 (82)	190 (88)	200 (93)	210 (99)	
Valve Pressure Rating psi (MPa)	1/2"-2"	PVC	200 (1.38)	135 (.93)	120 (.83)	75 (.52)	50 (.34)	-0- (-0-)	-0- (-0-)	-0- (-0-)	-0- (-0-)	-0- (-0-)	-0- (-0-)	
		CPVC	200 (1.38)	155 (1.07)	140 (.97)	125 (.86)	110 (.76)	100 (.69)	90 (.62)	80 (.55)	70 (.48)	60 (.41)	50 (.34)	-0- (-0-)
	2-1/2"-3"	PVC	150 (1.03)	130 (.90)	110 (.76)	60 (.41)	50 (.34)	-0- (-0-)	-0- (-0-)	-0- (-0-)	-0- (-0-)	-0- (-0-)	-0- (-0-)	-0- (-0-)
		CPVC	150 (1.03)	140 (.97)	130 (.90)	120 (.83)	110 (.76)	100 (.69)	90 (.62)	80 (.55)	70 (.48)	60 (.41)	50 (.34)	-0- (-0-)
	4"	PVC	235 (1.62)	140 (.97)	130 (.90)	90 (.62)	50 (.34)	-0- (-0-)	-0- (-0-)	-0- (-0-)	-0- (-0-)	-0- (-0-)	-0- (-0-)	-0- (-0-)
		CPVC	235 (1.62)	219 (1.51)	170 (1.17)	145 (1.00)	130 (.90)	110 (.76)	95 (.66)	80 (.55)	70 (.48)	60 (.41)	50 (.34)	-0- (-0-)

**NOT FOR USE WITH COMPRESSED AIR OR GASES**



# GATE VALVES

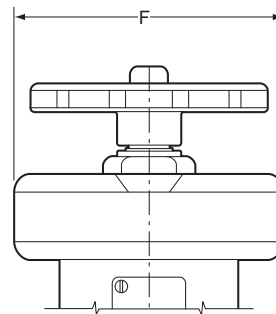
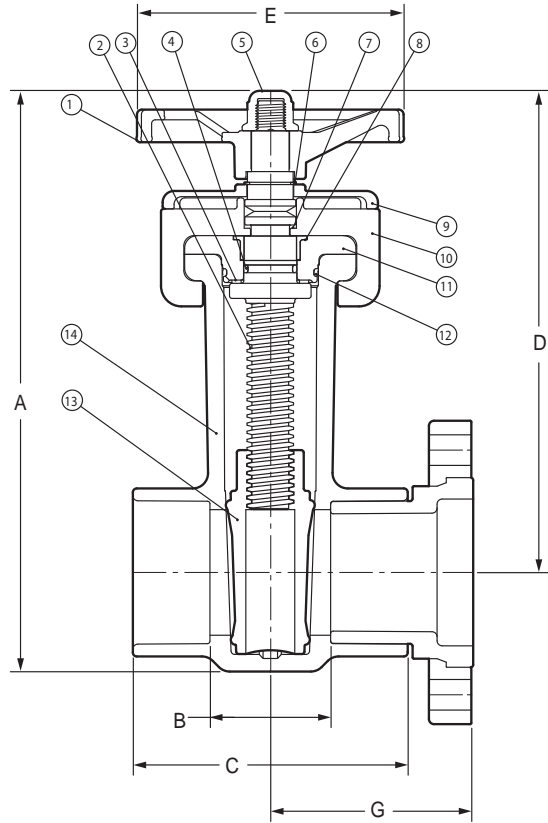
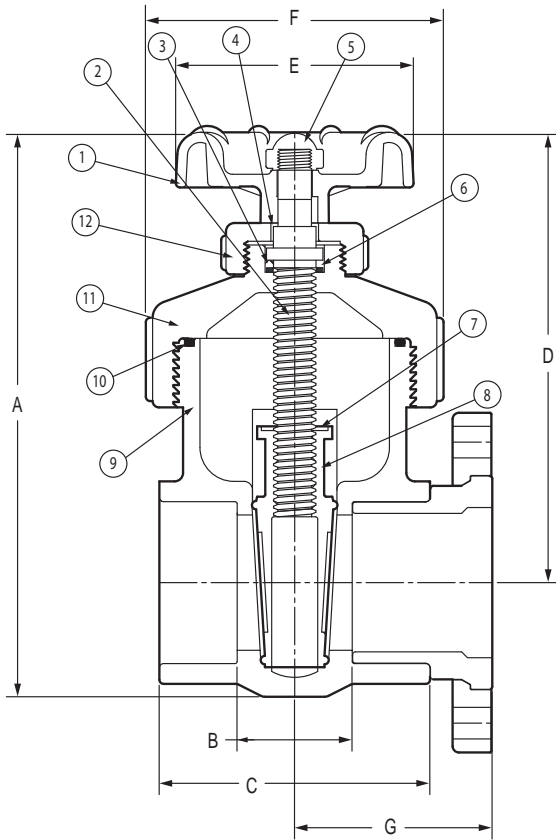

## 1/2" - 2" Replacement Parts

No.	Component	Qty.	Material
1	Handle	1	PP
2	Stem	1	PVC/CPVC
3	Stem O-ring	1	Buna-N/EPDM/Vition®
4	Stem Bushing	1	PP
5	Stem Nut	1	PVC/CPVC
6	Stem Washer	1	PP
7	Wedge Washer/O-ring	1	Buna-N/EPDM/Vition®
8	Wedge	1	PP/CPVC
9	Body (Socket/Threaded)	1	PVC/CPVC
10	Bonnet O-ring	1	Buna-N/EPDM/Vition®
11	Bonnet	1	PVC/CPVC
12	Bonnet Nut	1	PVC/CPVC

## 2-1/2" & 3" Replacement Parts

No.	Component	Qty.	Material
1	Handle	1	PP
2	Stem	1	PVC/CPVC
3	Stem Bearing	1	PP
4	Stem O-ring	1	Buna-N/EPDM/Vition®
5	Stem Nut	1	PVC
6	Stem Retaining Ring	1	SS 316
7	Split Washer	1	PP
8	Stem Bushing	1	PP
9	Bonnet Retainer	1	PVC/CPVC
10	Bonnet Half	2	PVC/CPVC
11	Seal Carrier	1	PVC/CPVC
12	Carrier O-ring	1	Buna-N/EPDM/Vition®
13	Wedge	1	PP/CPVC
14	Body	1	PVC/CPVC

# GATE VALVES

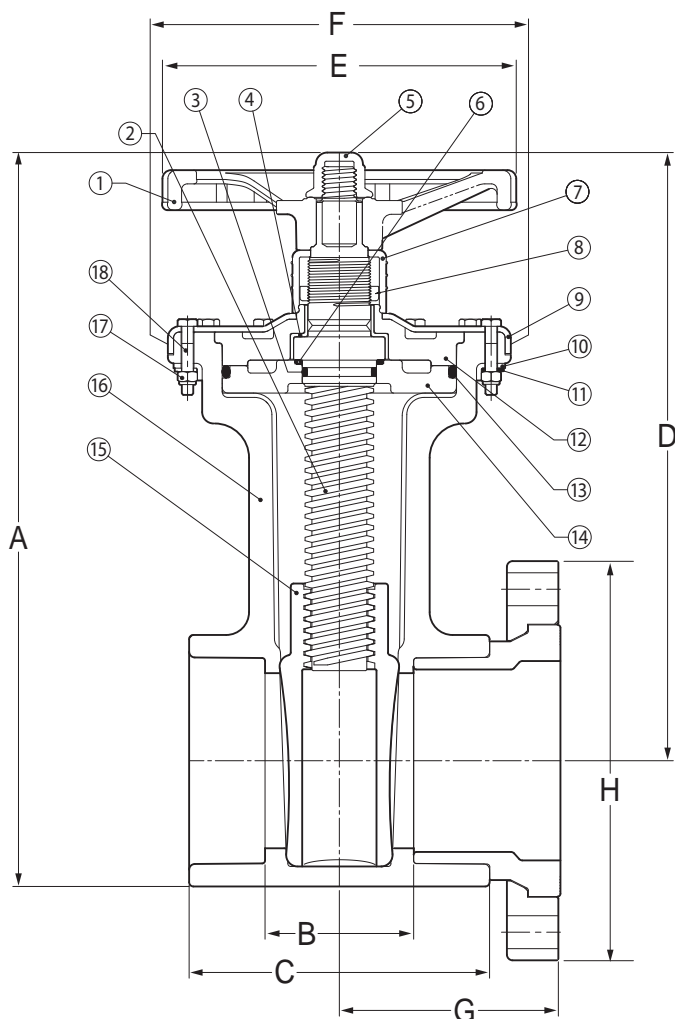

## 4" Replacement Parts

No.	Component	Qty.	Material
1	Handle	1	PP
2	Stem	1	PVC/CPVC
3	Stem O-ring	1	Buna-N/EPDM/Vition®
4	Stem Bushing	1	Poly Teflon®
5	Stem Nut	1	PVC/CPVC
6	Stem Washer	1	PP
7	Indicator Cover	1	PVC Clear
8	Indicator Nut	1	PP Yellow
9	Bonnet Retainer	1	SS 316
10	Retainer Bracket	2	SS 316
11	Bracket Lock	1	SS 316
12	Bonnet	1	PVC/CPVC
13	Seal Carrier O-ring	1	Buna-N/EPDM/Vition®
14	Seal Carrier	1	PVC/CPVC
15	Wedge	1	PP/CPVC
16	Body	1	PVC/CPVC
17	Locknut	12	SS 316
18	Hex Bolt	12	SS 316

## Dimensions & Weights

Nominal Size	Dimension Reference (inches, ± 1/16)								Approx. Wt. (Lbs.)			
	A	B <sup>1</sup>	C	D	E	F	G	H	PVC		CPVC	
									Soc/Thd	Flanged	Soc/Thd	Flanged
1/2	5-1/8	1-1/4	2-13/16	4-1/8	2-5/8	2-11/16	2-3/16	3-1/2	.51	.92	.56	.98
3/4	5-1/8	1-1/4	2-13/16	4-1/8	2-5/8	2-11/16	2-1/4	3-7/8	.52	1.09	.57	1.16
1	5-13/32	1-1/4	3-5/16	4-5/16	2-5/8	2-15/16	2-11/16	4-1/4	.67	1.46	.73	1.54
1-1/4	8-1/16	1-9/16	3-9/16	6-5/8	3-7/16	3-15/16	2-3/4	4-5/8	1.61	2.58	1.73	2.74
1-1/2	8-1/16	1-9/16	3-9/16	6-1/2	3-7/16	3-15/16	3-7/16	5	1.63	2.81	1.75	3.03
2	9-13/16	1-7/8	3-15/16	6-15/16	3-7/16	4-7/16	3-5/8	6	1.95	3.81	2.15	4.09
2-1/2	14-5/16	3-9/16	7-11/16	12-1/16	6-11/16	7-1/4	5-1/8	7-1/2	9.48	11.91	9.60	12.89
3	14-5/16	2-15/16	6-11/16	12-1/16	6-11/16	7-1/4	4-15/16	7-1/2	9.03	12.21	9.43	13.40
4	16	3-3/8	7-15/16	13-1/4	8	7-9/16	4-7/8	9	13.67	18.39	14.66	19.75

1: Valve Lay Length



## 2" Square / T-Style Operator Nuts

- Fits Spears® Gate Valves.
- Combination design for use with either standard 2" square drive or conventional "T" drive operators.

Size	Part Number
1/2, 3/4, 1	GTN-005
1-1/4, 1-1/2, 2	GTN-012
2-1/2 & 3	GTN-030
4	GTN-040