



GLOBE VALVES



Features - PVC, CPVC

Spears® Globe Valves provide close throttling control throughout the entire range of operation through positive shutoff. This makes the Globe Valve an excellent choice for throttling applications where pressure drop is not critical. Valves are available in PVC and CPVC materials in larger IPS sizes of 2-1/2" through 6" with Flanged end connections.

- Excellent Throttling Characteristics
- Chemical & Corrosion Resistant PVC or CPVC Construction – No Wetted Metal Parts
- Fully Serviceable In-line with Factory Assembled Internal Repair Kit
- Buna-N, EPDM or Viton® Seat & Seals
- Sizes 2-1/2" – 6" Pressure Rated to 150 psi @ 73°F
- Suitable for Vacuum Service
- Assembled with Silicone-Free, Water Soluble Lubricants

Sample Engineering Specification

All thermoplastic Globe valves shall be constructed from PVC Type I, ASTM D 1784 Cell Classification 12454 or CPVC Type IV, ASTM D 1784 Cell Classification 23447. All seals shall be Buna-N, EPDM or Viton®. All valves shall have a high impact polypropylene handwheel. All PVC and CPVC 2-1/2" through 6" valves shall be pressure rated to 150 psi for water at 73°F, as manufactured by Spears® Manufacturing Company.

Quick-View Valve Selection Chart

Valve Size	Seals	PVC Part Numbers ¹	Pressure Rating
		Flanged	
2-1/2	Buna-N ²	6013-025	150 psi Non-Shock Water @ 73°F
	EPDM	6023-025	
	Viton®	6033-025	
3	Buna-N ²	6013-030	
	EPDM	6023-030	
	Viton®	6033-030	
4	Buna-N ²	6013-040	
	EPDM	6023-040	
	Viton®	6033-040	
6	Buna-N ²	6013-060	
	EPDM	6023-060	
	Viton®	6033-060	

¹: For CPVC Globe Valves, add the letter "C" to the part number listed (e.g; 6023-025C).
²: Valves with Buna-N seals available in PVC only.

Globe Valve Internal Repair Kit

Internal Repair Kit includes: Bonnet O-ring (1) along with a factory assembled (required) internal component replacement unit consisting of Bonnet assembled with Stem O-rings, Seat and Seal Carrier components. Install in valve using existing valve Bolts, Nuts, Washers and Handle Nut.

Valve Size	Part Number				
	Buna-N O-ring	EPDM O-ring	CPVC w/EPDM O-ring	Viton® O-ring	CPVC w/Viton® O-ring
2-1/2	GL-BRK-025	GL-ERK-025	GL-ERK-025C	GL-VRK-025	GL-VRK-025C
3	GL-BRK-030	GL-ERK-030	GL-ERK-030C	GL-VRK-030	GL-VRK-030C
4	GL-BRK-040	GL-ERK-040	GL-ERK-040C	GL-VRK-040	GL-VRK-040C
6	GL-BRK-060	GL-ERK-060	GL-ERK-060C	GL-VRK-060	GL-VRK-060C

GLOBE VALVES

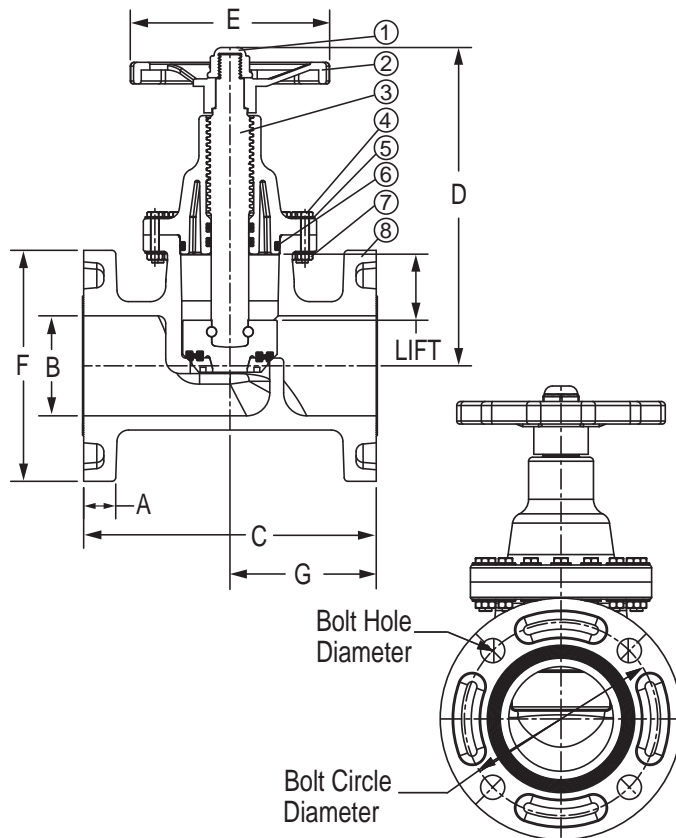

Replacement Parts

NO.	COMPONENT	QTY.	MATERIAL
1	Handle Nut	1	PVC
2	Handle	1	PP
3	Stem Assembly ¹	1	PVC/CPVC; BUNA-N/EPDM/VITON [®]
4	Hex Bolt	1	SS 316
5	Flat Washer	1	SS 316
6	Bonnet O-ring	1	BUNA-N/EPDM/VITON [®]
7	Hex Nut	1	SS 316
8	Body	1	PVC/CPVC

¹ - Stem Assembly Includes: Stem (1), Bonnet (1), Stem O-rings (2), Dowel Pins (2), Dowel Pin Plugs (2), Seal Carrier (1), Seat (1), Seat Retainer (1)

C_v Values

Nominal Size	C _v ¹
2-1/2	62
3	85
4	125
6	221

¹: Gallons per minute at 1 psi pressure drop.

Dimensions

Nominal Size	A	B	C	D (Open)	E	F	G	LIFT	Bolt Circle Diameter	Bolt Hole Diameter	Number of Bolt Holes
2-1/2	1-1/16	3-1/4	9-1/2	12-1/2	6-9/16	7-1/2	4-3/4	2-1/8	5-1/2	3/4	4
3	1-1/16	3-1/4	9-1/2	12-1/2	6-9/16	7-1/2	4-3/4	2-1/8	6	3/4	4
4	1-1/8	4-1/4	11-1/2	13-1/4	11	9	5-3/4	2-3/16	7-1/2	3/4	8
6	1-1/4	6-5/16	16-1/4	17-7/8	11	11	8-1/8	3-1/4	9-1/2	7/8	8

Temperature Pressure Rating

System Operating Temperature °F (°C)		73 (23)	100 (38)	110 (43)	120 (49)	130 (54)	140 (60)	150 (66)	160 (71)	170 (77)	180 (82)	190 (88)
Valve Pressure Rating psi (MPa)	PVC	150 (1.03)	124 (.85)	100 (.69)	75 (.52)	-0- (-0-)	-0- (-0-)	-0- (-0-)	-0- (-0-)	-0- (-0-)	-0- (-0-)	-0- (-0-)
	CPVC	150 (1.03)	140 (.97)	130 (.90)	120 (.83)	110 (.76)	100 (.69)	90 (.62)	80 (.55)	70 (.48)	60 (.41)	-0- (-0-)