

SWING CHECK BALL VALVES

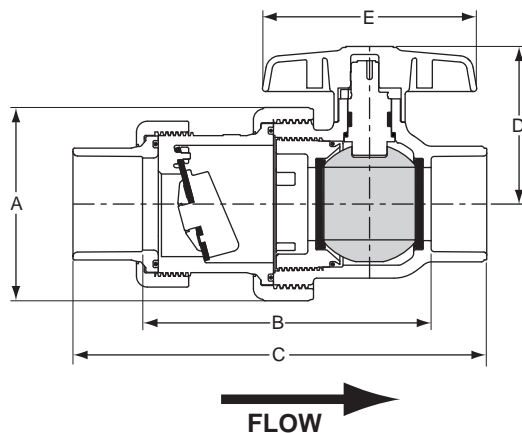

Sample Engineering Specification

All thermoplastic check valves shall be Swing Check Ball Valve combination type constructed from PVC Type I, ASTM D 1784 Cell Classification 12454. All Ball Valve units shall have Safe-T-Shear[®] stem, Safe-T-Blocked[®] Seal Carrier and double stop Polypropylene handle. All valve components shall be replaceable. All Swing Check Units shall be maintenance free seal unit construction with EPDM seat and weighted disc. All valves shall have external flow arrow designation. All valves shall be pressure rated to 150 psi for water @ 73°F in full flow (open) position and to 75 psi @ 73°F back pressure (closed), as manufactured by Spears[®] Manufacturing Company.



Dimensions

Size	A	B	C	D	E
1-1/2	3-7/8	5-3/4	8-1/4	3-3/16	4-1/4
2	4-7/16	6-11/16	9-3/8	3-7/8	5-1/16

Features - PVC White

Spears[®] Swing Check Ball Valve offers a compact, high performance one-piece combination valve for applications requiring an in-line Ball Valve and Check Valve. This space, time and labor saving valve is designed for general purpose use and in wastewater pumping applications, such as ejector pits. Provides quick shut-off for easy pump or equipment servicing. Fully serviceable Ball Valve with replaceable, maintenance free sealed Check Valve Cartridge featuring long-life EPDM elastomer seats and weighted disc for full-flow with minimal restriction and positive shutoff. Produced in PVC White with socket end connectors. Available in IPS sizes 1-1/2" and 2".

- Compact, Space-Saving Design
- Union Design Allows Easy Service and Cleaning
- High Grade EPDM Seats
- Replaceable Teflon[®] HDPE Ball Valve Seats
- Safe-T-Blocked[®] Seal Carrier on Ball Valve with Safe-T-Shear[®] Stem and High Impact Polypropylene Handle
- Replaceable Sealed Check Valve Cartridge with Weighted EPDM Seat
- Pressure Rated to 150 psi @ 73°F Full-Flow (open) and 75 psi @ 73°F Back Pressure (closed)
- Suitable for Horizontal or Vertical Up-flow Installations

General Installation Information: Swing Check Ball Valves are designed for horizontal installations, but may be installed in up-flow only vertical position. The Check Valve portion **MUST** be installed with the valve's **FLOW** arrow pointing in the direction of flow and with the designated side up in horizontal installations. Do Not install Check Valve upside down. The Ball Valve portion may be rotated and installed in any position. Flow velocity should not exceed 5 ft./sec. Minimum opening pressure is less than 0.5 psi.

Quick-View Swing Check Ball Valve Selection Chart

Valve Size	Seat Material	PVC Material	Pressure Rating
		Socket	
1-1/2	EPDM	7622-015	150 psi @ 73°F Full Flow (Open)
2	EPDM	7622-020	75 psi Back Pressure (Closed)

NOT FOR USE WITH COMPRESSED AIR OR GASES