

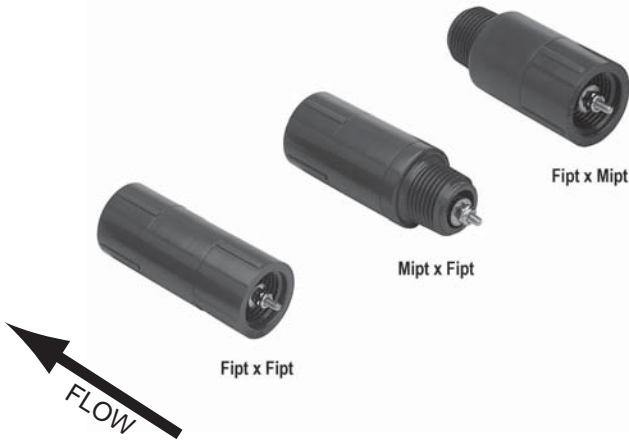

IN-LINE ADJUSTABLE SPRING CHECK VALVES



Features - PVC

Adjustable feature allows control of back pressure in system, reduces water hammer, and prevents siphoning. Easily adjusts to hold back from 5 to 32 feet of pressure head, 1 psi (2.3 feet of head) for each full turn of the adjustment screw. Ideal for landscape and irrigation applicators, quickly installs with space saving in-line design.

- 2 - 14 lbs. Adjustable Spring Tension (5 to 32 feet of head) Factory Preset to Approx. 5 psi (12 feet of head)
- Stainless Steel Adjustment Spring with EPDM Seat
- Pressure Rated to 200 psi for Water @ 73°F
- Standard Unit Available in 1/2", 3/4", 1" & 1/2" x 3/4" with Fipt Inlet x Mipt Outlet Configuration
- Plus, Popular Configuration Options of 1/2" Mipt Inlet x Fipt Outlet & 3/4" Fipt Inlet x Fipt Outlet

Sample Engineering Specification

All thermoplastic check valves shall be Adjustable Spring Check type constructed from PVC Type I, ASTM D 1784 Cell Classification 12454. All Valve Seats shall be EPDM. All valves shall have external Arrow Flow Indicator. All valves shall be pressure rated to 200 psi water at 73°F, as manufactured by Spears® Manufacturing Company.

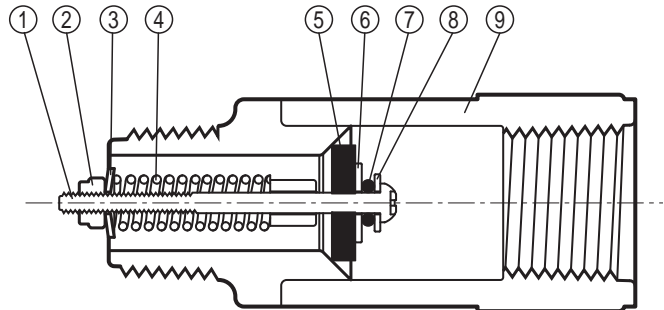

Quick-View Valve Selection Chart

Standard Unit - Female Inlet x Male Outlet		
Size	Part Number	Configuration
1/2	S1102-05	Fipt x Mipt (Inlet x Outlet)
3/4	S1102-07	Fipt x Mipt (Inlet x Outlet)
1	S1102-10	Fipt x Mipt (Inlet x Outlet)
1/2 x 3/4	S1102-05-07	Fipt x Mipt (Inlet x Outlet)
Male Inlet x Female Outlet Option		
Size	Part Number	Configuration
1/2	S1101-05	Mipt x Fipt (Inlet x Outlet)
Female Inlet x Female Outlet Option		
Size	Part Number	Configuration
3/4	S1100-07	Fipt x Fipt (Inlet x Outlet)

Replacement Parts

No.	Component	Qty.	Material
1	Screw	1	Stainless Steel
2	Nut	1	Stainless Steel
3	Belleville Washer	1	Stainless Steel
4	Spring	1	Stainless Steel
5	Seat	1	EPDM
6	Washer - A	1	Stainless Steel
7	O-ring	1	EPDM
8	Washer - B	1	Stainless Steel
9	Body	1	PVC

IN-LINE ADJUSTABLE SPRING CHECK VALVES

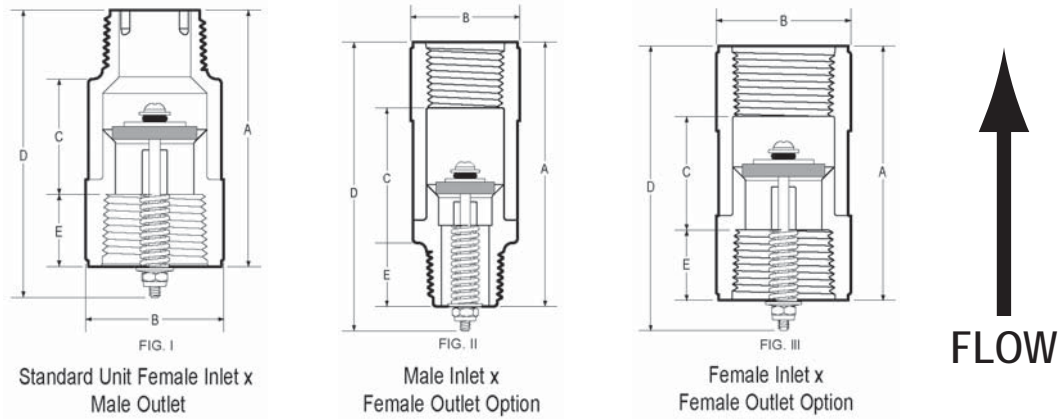

Dimensions

SIZE	INLET X OUTLET	A ± 1/16	B ± 1/16	C ± 1/16	D ± 1/16	E ± 1/16	FIG.
1/2	FIPT X MIPT	2-5/8	1-3/16	1-3/16	2-3/4	3/4	I
3/4	FIPT X MIPT	2-5/8	1-3/8	1-3/16	2-15/16	3/4	I
1	FIPT X MIPT	3-3/16	1-11/16	1-7/16	3-7/16	7/8	I
1/2 x 3/4	FIPT X MIPT	2-5/8	1-3/8	1-3/16	2-15/16	3/4	I
1/2	MIPT X FIPT	2-7/8	1-3/16	1-7/16	3-1/8	3/4	II
3/4	FIPT X FIPT	2-5/8	1-3/8	1-3/16	2-15/16	3/4	III

Temperature Pressure Rating

System Operating Temperature °F (°C)			100 (38)	110 (43)	120 (49)	130 (54)	140 (60)	150 (66)	160 (71)	170 (77)	180 (82)	190 (88)	200 (93)	210 (99)
Valve Pressure Rating psi (MPa)	1/2"-1"	PVC	200 (1.38)	135 (.93)	120 (.83)	75 (.52)	50 (.34)	-0- (-0-)	-0- (-0-)	-0- (-0-)	-0- (-0-)	-0- (-0-)	-0- (-0-)	-0- (-0-)