



GENERAL INSTALLATION

Ease of installation and maintenance is one of the major advantages of using thermoplastic valves. As with any product, certain procedures must be followed for successful installation, service and long life. This section specifies individual installation and maintenance service instructions for Spears® valves. All applicable instructions and procedures should be read thoroughly before starting. Suitability of the intended service application should be determined prior to installation. Please review **“Material Considerations in Application and System Design”**, in the **“MATERIALS”** section of this manual for important additional considerations related valve installations.

Plastic piping systems should be engineered, installed, operated and maintained in accordance with accepted standards and procedures for plastic piping systems. It is absolutely necessary that all design, installation, operation and maintenance personnel be trained in proper handling, installation requirements and precautions for installation and use of plastic piping systems before starting.

Individual valve installation instructions specific to each product type are packaged with product. The following sections of this manual contain safety precautions and procedures for making solvent cement, threaded or flanged joints.

Precautions & Warnings for All Valve, Strainer & Accessories Installations

CAUTION: *The system shall be designed and installed so as not to pull the valve in any direction. Valve and strainers must be supported with conventional piping system support devices.*

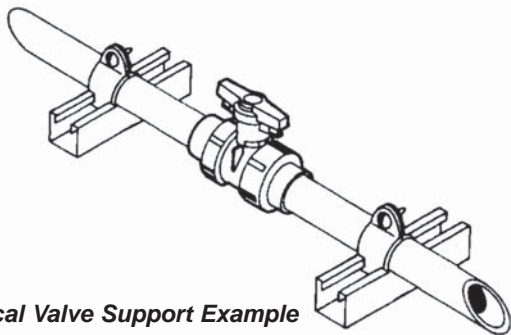

Typical Valve Support Example

CAUTION: *All valve connectors and connecting pipe should be inspected for any breaking, chipping, gouging or other visible damage before proceeding. All joining components must be clean and dry. All valves and pipe shall be removed from their packaging or containers and exposed to the environment for a minimum of one hour in order to thermally balance all components. Installation temperatures should be between 40°F and 110°F.*

CAUTION: *All valves with fixed socket end connectors in the body must be installed in the open position to aid in evaporation of solvent vapors which can attack internal components. **WARNING: TAKE EXTRA CARE THAT NO PRIMER OR SOLVENT CEMENT IS ALLOWED TO COME IN CONTACT WITH THE BALL OR OTHER INTERNAL VALVE COMPONENTS.***

CAUTION: *Threaded pipe connections require application of a quality grade thread sealant to seal joint assembly. Sealant should be applied to male pipe threads. **WARNING: SOME PIPE JOINT COMPOUNDS OR TEFLON® PASTES MAY CONTAIN SUBSTANCES THAT COULD CAUSE STRESS CRACKING IN THERMOPLASTIC MATERIALS.***

*Spears® Manufacturing Company recommends the use of Spears® **BLUE 75™** thread sealant which has been tested for compatibility with Spears® products. Please follow the sealant manufacturers' application / installation instructions. Choice of an appropriate thread sealant other than those listed above is at the discretion of the installer.*

CAUTION: ***BEFORE THE VALVE IS CYCLED,** all dirt, sand, grit or other material shall be flushed from the system. This is to prevent scarring of internal components; e.g., ball, cup, wedge, seats, etc.*

WARNING: ***Some Lubricants, including vegetable oils, are known to cause stress cracking in thermoplastic materials.** All lubricants should be checked for compatibility with PVC, CPVC or other thermoplastic products. Formulation changes by lubricant manufacturers may alter compatibility of previously acceptable materials and are beyond our control. Choice of lubricant is at the discretion of the installer.*

WARNING: *DO NOT USE COMPRESSED AIR OR GAS TO TEST ANY PVC OR CPVC THERMOPLASTIC PIPING PRODUCT OR SYSTEM, AND DO NOT USE DEVICES PROPELLED BY COMPRESSED AIR OR GAS TO CLEAR SYSTEMS. THESE PRACTICES MAY RESULT IN EXPLOSIVE FRAGMENTATION OF SYSTEM PIPING AND COMPONENTS CAUSING SERIOUS OR FATAL BODILY INJURY. All air must be bled from the system during initial fluid fill. Pressure testing of the system should not be made until all solvent cement joints have properly cured. Initial pressure testing should be made at approximately 10% of the system hydrostatic pressure rating to identify potential problems, prior to testing at higher pressures.*

WARNING: *Systems should not be operated or flushed out at flow velocities greater than 5 feet per second.*