



# True Union 2000 Standard Ball Valves



## Sample Engineering Specification

All thermoplastic ball valves shall be True Union 2000 Standard type manufactured to ASTM F 1970 and constructed from PVC Type I, ASTM D 1784 Cell Classification 12454 or CPVC Type IV, ASTM D 1784 Cell Classification 23447. All O-rings shall be EPDM or FKM. All valves shall have Safe-T-Shear® stem with O-ring stem seal. All handles shall be polypropylene. All union nuts shall have Buttress threads. All seal carriers shall be Safe-T-Blocked®. All EPDM valves shall be certified by NSF International for use with potable water. All 1/2" - 2" valves shall be pressure rated to 235 psi, all 2-1/2" - 4" and all flanged valves to 150 psi for water @ 73°F, as manufactured by Spears® Manufacturing Company.

## Features – PVC, CPVC

Economical, low profile quarter-turn shutoff valve is excellent for general purpose and many O.E.M applications. PVC and CPVC valves are available in IPS sizes 1/2" through 4" with socket, regular thread, SR threaded (Special Reinforced), flanged or spigot end connectors.

- Chemical & Corrosion Resistant PVC or CPVC Construction
- Interchangeable with all True Union 2000 Valves, Mates with Union 2000 Pipe Unions
- High Impact Polypropylene Handle
- Schedule 80 Full-Bore Design
- Strong, Buttress Thread Union Nuts
- Spears® Single O-ring Safe-T-Shear® Stem Design
- Spears® Safe-T-Blocked® Seal Carrier
- Replaceable PTFE/HDPE Floating Seat Design
- EPDM or FKM O-rings
- Sizes 1/2" - 2" pressure rated to 235 psi @ 73°F
- Sizes 2-1/2" - 4" and all flanged pressure rated to 150 psi @ 73°F
- EPDM valves NSF® Certified for Potable Water use
- Suitable for Vacuum Service
- Assembled with Silicone-Free, Water Soluble Lubricants
- Manufactured to ASTM F 1970

## Quick-View Valve Selection Chart

Valve Size	O-ring Material	PVC Part Number <sup>1</sup>					Pressure Rating
		Socket	Threaded	SR Threaded	Flanged	Spigot	
1/2	EPDM	3629-005	included	3621-005SR	3623-005	3627-005	235 psi Non-Shock Water @ 73°F
	FKM	3639-005	included	3631-005SR	3633-005	3637-005	
3/4	EPDM	3629-007	included	3621-007SR	3623-007	3627-007	
	FKM	3639-007	included	3631-007SR	3633-007	3637-007	
1	EPDM	3629-010	included	3621-010SR	3623-010	3627-010	
	FKM	3639-010	included	3631-010SR	3633-010	3637-010	
1-1/4	EPDM	3629-012	included	3621-012SR	3623-012	3627-012	(Flanged 150 psi Non-Shock) Water @ 73°F
	FKM	3639-012	included	3631-012SR	3633-012	3637-012	
1-1/2	EPDM	3629-015	included	3621-015SR	3623-015	3627-015	
	FKM	3639-015	included	3631-015SR	3633-015	3637-015	
2	EPDM	3629-020	included	3621-020SR	3623-020	3627-020	
	FKM	3639-020	included	3631-020SR	3633-020	3637-020	
2-1/2	EPDM	3622-025	3621-025	3621-025SR	3623-025	3627-025	150 psi Non-Shock Water @ 73°F
	FKM	3632-025	3631-025	3631-025SR	3633-025	3637-025	
3	EPDM	3622-030	3621-030	3621-030SR	3623-030	3627-030	
	FKM	3632-030	3631-030	3631-030SR	3633-030	3637-030	
4	EPDM	3622-040	3621-040	3621-040SR	3623-040	3627-040	
	FKM	3632-040	3631-040	3631-040SR	3633-040	3637-040	

<sup>1</sup>: For CPVC valve, add the letter "C" to the part number (e.g., 3629-005C, 3621-005CSR)

## Optional Accessories\*

- Retro-Fit End Connector Sets for Valve Replacement
- Split-Nut Repair Kits for Union Nut Replacement
- Supplemental End Connectors
- Round Safety Handles
- Stem Extension Kits
- Square Operator Nuts
- Multi Mount Valve/ Actuation Mounting Kits
- Mini-Mount Actuation Mounting Kits

\* See "BALL VALVE ACCESSORIES" section for details of individual products.

# True Union 2000 Standard Ball Valves

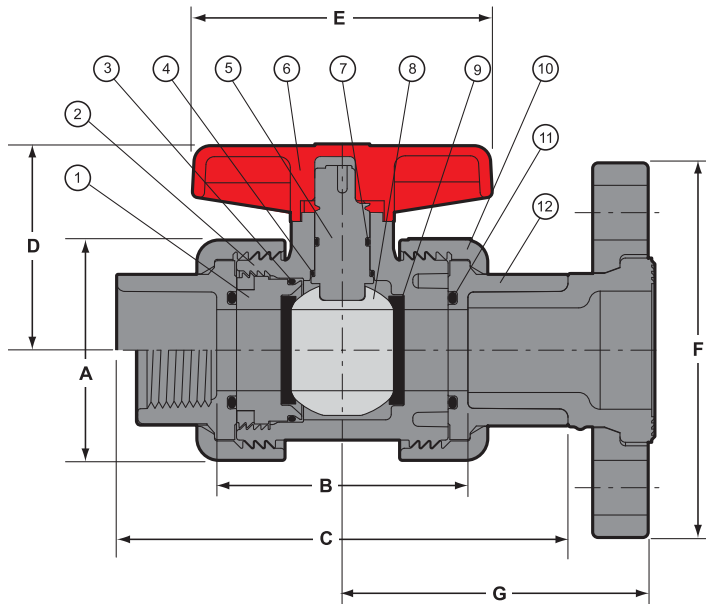

## Replacement Parts

No.	Component	Qty.	Material
1	Seal Carrier	1	PVC/CPVC
2	Body	1	PVC/CPVC
3	Carrier O-ring	1	EPDM/FKM
4	Stem Bearing 1,2	1	PP
5	Stem	1	PVC/CPVC
6	Handle	1	PP
7	Stem O-ring	1	EPDM/FKM
8	Ball	1	PVC/CPVC
9	Seat	2	PTFE/HDPE
10	Union Nut	2	PVC/CPVC
11	End Connector O-ring	2	EPDM/FKM
12	End Connector	2	PVC/CPVC

1: O-Ring up to 2"

2: PTFE Thrust Bearing: 2-1/2", 3" & 4"

## Dimensions, Weights, Operating Torque & Cv Values

Nominal Size	A	B <sup>1</sup>		C			D	E	F	G	Approx. Wt. (Lbs.)		Oper. <sup>2</sup> Torque (in. lbs.)	Cv Values <sup>3</sup>	
		Soc/Thd	Spigot	Socket	Thread	Spigot					PVC	CPVC		Soc/Thd/Spig	Flanged
1/2	1-7/8	2-7/16	2-7/8	4-3/16	3-13/16	4-5/8	1-5/8	2-1/2	3-1/2	2-31/32	.33	.35	12	29	18
3/4	2-1/4	2-3/4	3-1/4	4-3/4	4-1/4	5-1/4	2	3	3-7/8	3-5/16	.51	.54	20	63	39
1	2-1/2	2-7/8	3-1/2	5-1/8	4-11/16	5-3/4	2-5/16	3-7/16	4-1/4	3-5/8	.71	.75	25	120	73
1-1/4	3-1/16	3-1/4	3-13/16	5-3/4	5-3/16	6-5/16	2-13/16	3-9/16	4-5/8	3-31/32	1.12	1.17	35	243	151
1-1/2	3-1/2	3-1/2	4	6-1/4	5-7/16	6-3/4	3-1/16	3-7/8	5	4-3/8	1.47	1.53	45	357	223
2	4-1/4	4-3/4	5-13/16	7-3/4	6-3/4	8-1/4	3-3/4	5	6	5-1/4	2.62	2.75	94	599	395
2-1/2	6-3/16	7	7-13/16	10-1/2	8-1/2	11-3/8	5-7/8	7-5/8	7	6	7.42	7.70	120	856	579
3	6-3/16	7	7-13/16	10-11/16	9-3/4	11-9/16	5-7/8	7-5/8	7-1/2	6-13/16	7.46	7.81	120	1416	974
4	7-5/8	7-1/2	8-1/4	12-1/16	10-1/4	12-3/4	6-3/4	6-3/4	9-1/16	7-1/2	12.35	12.48	336	2865	1952

1: Valve Lay Length

2: Torque required at valve maximum internal pressure rating, 5ft/sec. Flow velocity; due to adjustment differences during installation, actual valves may vary.

3: Gallons per minute at 1 psi pressure drop. Valves calculated from laying length, based on derivative of Hazen-Williams equation with surface roughness factor of C=150.

## Temperature Pressure Rating

System Operating Temperature °F (°C)			100 (38)	110 (43)	120 (49)	130 (54)	140 (60)	150 (66)	160 (71)	170 (77)	180 (82)	190 (88)	200 (93)	210 (99)
Valve Pressure Rating (MPa)	1/2" - 2"	PVC	235 (1.62)	211 (1.45)	150 (1.03)	75 (.52)	50 (.34)	-0- (-0-)	-0- (-0-)	-0- (-0-)	-0- (-0-)	-0- (-0-)	-0- (-0-)	-0- (-0-)
		CPVC	235 (1.62)	219 (1.51)	170 (1.17)	145 (1.00)	130 (.90)	110 (.76)	90 (.62)	80 (.55)	70 (.48)	60 (.41)	50 (.34)	-0- (-0-)
	2-1/2" - 4"	PVC	150 (1.03)	135 (.93)	110 (.76)	75 (.52)	50 (.34)	-0- (-0-)	-0- (-0-)	-0- (-0-)	-0- (-0-)	-0- (-0-)	-0- (-0-)	-0- (-0-)
		CPVC	150 (1.03)	140 (.97)	130 (.90)	120 (.83)	110 (.76)	100 (.70)	90 (.62)	80 (.55)	70 (.48)	60 (.41)	50 (.34)	-0- (-0-)