



TRUE UNION 2000 INDUSTRIAL BALL CHECK VALVES



Features – PVC, CPVC

Flow tested design provides quick response with positive seal for prevention of system back flow in industrial and chemical processing applications. Valves are available in IPS sizes 1/2" through 6" with socket/regular thread, SR threaded (Special Reinforced), flanged or spigot end connectors and 8" venturied valve with socket or flanged ends. Also available in metric socket and BSP thread sizes 1/2" through 2".

Sample Engineering Specification

All thermoplastic check valves shall be True Union 2000 Industrial Ball Check type manufactured to ASTM F 1970 and constructed from PVC Type I, ASTM D 1784, Cell Classification 12454 or CPVC Type IV, ASTM D 1784 Cell Classification 23447. All O-rings shall be EPDM or FKM. All valve union nuts shall have Buttress threads. All valve seats shall be a standard O-ring type. All seal carriers shall be Safe-T-Blocked®. All valve components shall be replaceable. All EPDM valves shall be listed by NSF® for use in potable water service. All PVC and CPVC 1/2" through 4" valves shall be pressure rated to 235 psi, all 6" and 8" Venturied and all flanged valves shall be pressure rated to 150 psi for water at 73°F as manufactured by Spears® Manufacturing Company.

- Chemical & Corrosion Resistant PVC or CPVC Construction
- Also Available in Spears® High Purity, Low Extractable PVC Material
- Strong, Buttress Thread Union Nuts
- Spears® Safe-T-Blocked® Seal Carrier
- Uses Standard O-ring Seat
- EPDM or FKM O-rings
- Fully Serviceable, Replaceable Components
- Sizes 1/2" - 4" Pressure Rated to 235 psi @ 73°F, Sizes 6" and 8" Venturied and all Flanged Pressure Rated to 150 psi @ 73°F
- Suitable for Either Horizontal or Vertical Installations
- EPDM valves NSF® Certified for Potable Water use
- Suitable for Vacuum Service
- Assembled with Silicone-Free, Water Soluble Lubricants

Quick-View Valve Selection Chart

Valve Size	O-ring Material	PVC Part Number ¹					Pressure Rating
		Socket	Threaded	SR Threaded	Flanged	Spigot	
1/2	EPDM	4529-005	included	4521-005SR	4523-005	4527-005	235 psi Non-Shock Water @ 73°F (Flanged 150 psi Non-Shock) Water @ 73°F
	FKM	4539-005	included	4531-005SR	4533-005	4537-005	
3/4	EPDM	4529-007	included	4521-007SR	4523-007	4527-007	
	FKM	4539-007	included	4531-007SR	4533-007	4537-007	
1	EPDM	4529-010	included	4521-010SR	4523-010	4527-010	
	FKM	4539-010	included	4531-010SR	4533-010	4537-010	
1-1/4	EPDM	4529-012	included	4521-012SR	4523-012	4527-012	
	FKM	4539-012	included	4531-012SR	4533-012	4537-012	
1-1/2	EPDM	4529-015	included	4521-015SR	4523-015	4527-015	
	FKM	4539-015	included	4531-015SR	4533-015	4537-015	
2	EPDM	4529-020	included	4521-020SR	4523-020	4527-020	
	FKM	4539-020	included	4531-020SR	4533-020	4537-020	
2-1/2	EPDM	4522-025	4521-025	4521-025SR	4523-025	4527-025	
	FKM	4532-025	4531-025	4531-025SR	4533-025	4537-025	
3	EPDM	4522-030	4521-030	4521-030SR	4523-030	4527-030	
	FKM	4532-030	4531-030	4531-030SR	4533-030	4537-030	
4	EPDM	4522-040	4521-040	4521-040SR	4523-040	4527-040	
	FKM	4532-040	4531-040	4531-040SR	4533-040	4537-040	
6	EPDM	4522-060	4521-060	4521-060SR	4523-060	4527-060	
	FKM	4532-060	4531-060	4531-060SR	4533-060	4537-060	
8 ²	EPDM	4522-080	—	—	4523-080	—	
	FKM	4532-080	—	—	4533-080	—	

1: For CPVC valve, add the letter "C" to the part number (e.g., 4529-005C, 4521-005CSR)
 2: 8" Venturied Valves are 6" ball valves fitted with 6x8 end connector adapters

Optional Accessories*

- Retro-Fit End Connector Sets for Valve Replacement
- Split-Nut Repair Kits for Union Nut Replacement
- Supplemental End Connectors

* See "BALL VALVE ACCESSORIES" section for details of individual products.

Ball Check Foot Valves



Spears® Ball Check Valves easily convert to foot valves utilizing optional Foot Valve Screen adapters found in Ball Valve Accessories section.

TRUE UNION 2000 INDUSTRIAL BALL CHECK VALVES

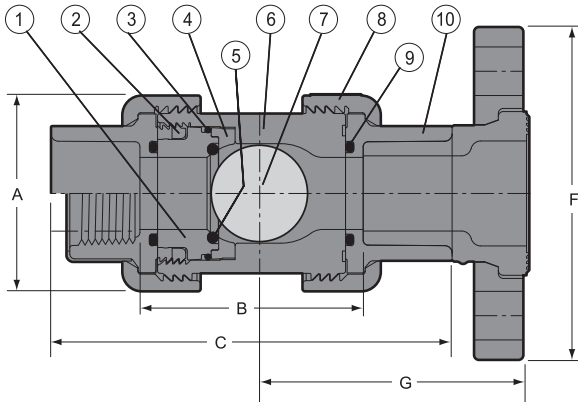

Replacement Parts

No.	Component	Qty.	Material
1	Seal Carrier	1	PVC/CPVC
2	Seal Carrier Nut	1	PVC/CPVC
3	Carrier O-ring	1	EPDM/FKM
4	Seat Plate	1	PVC/CPVC
5	Seat O-ring	1	EPDM/FKM
6	Body	1	PVC/CPVC
7	Ball	1	PVC/CPVC
8	Union Nut	2	PVC/CPVC
9	End Connector O-ring	2	EPDM/FKM
10	End Connector	2	PVC/CPVC

Dimensions, Weights, & Cv Values

Nominal Size	Dimensions Reference (inches, ± 1/16)							Approx. Wt. (Lbs.)		Cv Values			Horizontal Closing		
	A	B ¹		C			F	G	PVC	CPVC	Soc/Thd	Flange	Spigot	Feet of Head (water)	GPM (minimum)
		Soc/Thd	Spigot	Socket	Thread	Spigot									
1/2	1-7/8	2-7/16	2-7/8	4-3/16	3-13/16	4-5/8	3-1/2	2-31/32	.30	.33	6.3	6	6.3	1.6	.10
3/4	2-1/4	2-3/4	3-1/4	4-3/4	4-1/4	5-1/4	3-7/8	3-5/16	.46	.50	17	16	17	1.6	.10
1	2-1/2	2-7/8	3-1/2	5-1/8	4-11/16	5-3/4	4-1/4	3-5/8	.70	.74	25	24	25	1.6	.25
1-1/4	3-1/16	3-1/4	3-3/16	5-3/4	5-3/16	6-5/16	4-5/8	3-31/32	1.04	1.09	65	61	65	1.6	.40
1-1/2	3-1/2	3-1/2	4	6-1/4	5-7/16	6-3/4	5	4-3/8	1.37	1.45	86	82	86	1.6	.75
2	4-1/4	4-3/4	5-3/16	7-3/4	6-3/4	8-1/4	6	5-1/4	2.47	2.62	130	125	130	1.6	.75
2-1/2	6-3/16	5-7/8	7-13/16	9-5/16	8-1/2	11-3/8	7-1/2	6	6.80	7.25	200	193	200	1.0	1.50
3	6-3/16	6-7/8	7-13/16	10-11/16	9-3/4	11-9/16	7-1/2	6-13/16	6.98	7.35	275	268	275	1.0	4.00
4	7-1/2	7-1/4	8-1/4	11-13/16	10-1/4	12-3/4	9	7-1/2	12.13	12.96	500	489	500	1.0	5.50
6	11-5/8	11-1/6	13	17-1/16	15-3/4	18-1/2	11-1/4	10-3/16	37.07	39.98	800	794	800	N/A	N/A
8 ³	11-5/8	23-3/16	---	31-7/8	---	---	13-1/2	17-13/16	50.84	55.92	N/A	N/A	N/A	N/A	N/A

1: Valve Lay Length

2: Gallons per minute at 1 psi pressure drop. Valves calculated from laying length, based on derivative of Hazen-Williams equation with surface roughness factor of C=150.

3: 8" Venturied Valves are 6" ball valves fitted with 6x8 end connector adapters

Temperature Pressure Rating

System Operating Temperature °F (°C)		100 (38)	110 (43)	120 (49)	130 (54)	140 (60)	150 (66)	160 (71)	170 (77)	180 (82)	190 (88)	200 (93)	210 (99)	
Valve Pressure Rating psi (MPa)	1/2" - 4"	PVC	235 (1.62)	211 (1.45)	150 (1.03)	75 (.52)	50 (.34)	-0- (-0-)	-0- (-0-)	-0- (-0-)	-0- (-0-)	-0- (-0-)	-0- (-0-)	
		CPVC	235 (1.62)	219 (1.51)	170 (1.17)	145 (1.00)	130 (.90)	110 (.76)	90 (.62)	80 (.55)	70 (.48)	60 (.41)	50 (.34)	-0- (-0-)
	6" and 8"	PVC	150 (1.03)	135 (.93)	110 (.76)	75 (.52)	50 (.34)	-0- (-0-)	-0- (-0-)	-0- (-0-)	-0- (-0-)	-0- (-0-)	-0- (-0-)	-0- (-0-)
		CPVC	150 (1.03)	140 (.97)	130 (.90)	120 (.83)	110 (.76)	100 (.70)	90 (.62)	80 (.55)	70 (.48)	60 (.41)	50 (.34)	-0- (-0-)

NOTE: Flanged valves have a base pressure rating of 150 psi

General Installation Information: Ball check valves may be installed in either horizontal or vertical position. A minimum of ten (10) pipe diameters distance maintained from any pump or other source of turbulence. Check valves **MUST** be installed with the valves **FLOW** arrow pointing in the direction of flow.

NOT FOR DISTRIBUTION OF COMPRESSED AIR OR GASES