



COMPACT 2000 BALL VALVES



Sample Engineering Specification

All thermoplastic ball valves shall be 2000 Compact sealed unit type manufactured to ASTM F 1970 and constructed from PVC Type I, ASTM D 1784 Cell Classification 12454 or CPVC Type IV, ASTM D 1784 Cell Classification 23447. All O-rings shall be EPDM or FKM. All valves shall have Safe-T-Shear[®] stem with O-ring stem seal. All handles shall be polypropylene. All EPDM valves shall be certified by NSF[®] International for use with potable water. All 1/2" - 2" valves shall be pressure rated to 235 psi, for water @ 73°F, as manufactured by Spears[®] Manufacturing Company.

Features – PVC, CPVC

Economical, low profile quarter-turn shutoff valve is excellent for general purpose and many O.E.M applications. PVC and CPVC valves are available in IPS sizes 1/2" through 2" with socket and regular thread.

- Industrial Grade, Maintenance-Free Sealed Unit
- New Actuator-Ready Body – Accepts Spears[®] Improved Mini-Mount Actuator Mounting Kits
- New Double O-ring Stem Seal
- Spears[®] Safe-T-Shear Stem
- PTFE Self Adjusting Floating Seats
- EPDM or FKM O-ring Seals
- Full 235 psi Pressure Rating @ 73°F
- EPDM valves NSF[®] Certified for Use with Potable Water
- Suitable for Vacuum Service
- Produced in ASTM IPS sizes 1/2" - 2" with Socket or Threaded End Connectors.

Optional Accessories*

- Round Safety Handles
- Stem Extension Kits
- Square Operator Nuts
- Multi Mount Valve/Actuation Mounting Kits
- Mini-Mount Actuation Mounting Kits

* See "BALL VALVE ACCESSORIES" section for details of individual products.

Quick-View Valve Selection Chart

Valve Size	O-ring Material	PVC Part Number ¹		Pressure Rating
		Socket	Threaded	
1/2	EPDM	6622-005	6621-005	235 psi Non-Shock Water @73°F
	FKM	6632-005	6631-005	
3/4	EPDM	6622-007	6621-007	
	FKM	6632-007	6631-007	
1	EPDM	6622-010	6621-010	
	FKM	6632-010	6631-010	
1-1/4	EPDM	6622-012	6621-012	
	FKM	6632-012	6631-012	
1-1/2	EPDM	6622-015	6621-015	
	FKM	6632-015	6631-015	
2	EPDM	6622-020	6621-020	
	FKM	6632-020	6631-020	

1: For CPVC Valves, add the letter "C" to part numbers listed. (e.g., 6622-005C)

NOT FOR DISTRIBUTION OF COMPRESSED AIR OR GASES

COMPACT 2000 BALL VALVES

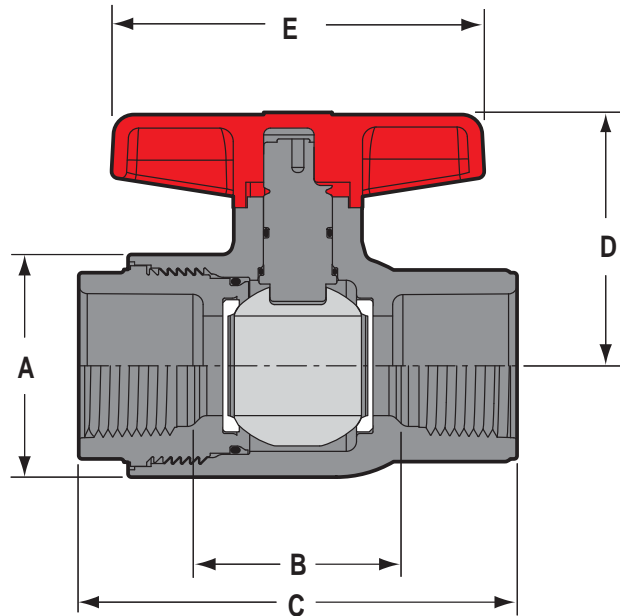

Dimensions, Weights, Operating Torque & Cv Values

Nominal Size	Dimension Reference (inches, $\pm 1/16$)						Approx. Wt. (Lbs.)		Oper. ² Torque (in.-lb.)	Cv ³ Values
	A	B ¹		C	D	E	PVC	CPVC		
		Socket	Threaded							
1/2	1-7/16	1-1/4	1-5/8	3-1/16	1-5/8	1-5/8	.18	.20	10	42
3/4	1-13/16	1-1/2	2-1/16	3-9/16	2	2	.29	.31	20	87
1	2-1/16	1-3/4	2-3/16	4	2-5/16	2-5/16	.44	.46	25	157
1-1/4	2-5/8	2-1/6	2-3/4	4-5/8	2-13/16	2-13/16	.68	.70	30	311
1-1/2	3	2-1/2	3-3/8	5-5/16	3-1/16	3-1/16	.99	1.03	50	429
2	3-5/8	3	4	6	3-3/4	3-3/4	1.64	1.70	90	768

1: Valve Lay Length

2: Torque required at valve maximum internal pressure rating, 5ft/sec. Flow velocity.

3: Gallons per minute at 1 psi pressure drop. Valves calculated from laying length, based on derivative of Hazen-Williams equation with surface roughness factor of C=150.

Temperature Pressure Rating

System Operating Temperature °F (°C)		100 (38)	110 (43)	120 (49)	130 (54)	140 (60)	150 (66)	160 (71)	170 (77)	180 (82)	190 (88)	200 (93)	210 (99)
Valve Pressure Rating psi (MPa)	1/2" - 2"	PVC	235 (1.62)	211 (1.45)	150 (1.03)	75 (.52)	50 (.34)	-0- (-0-)	-0- (-0-)	-0- (-0-)	-0- (-0-)	-0- (-0-)	-0- (-0-)
		CPVC	235 (1.62)	219 (1.51)	170 (1.17)	145 (1.00)	130 (.90)	110 (.76)	90 (.62)	80 (.55)	70 (.48)	60 (.41)	50 (.34)

NOT FOR DISTRIBUTION OF COMPRESSED AIR OR GASES